

Setup

Location and Mounting

The *Pioneer* heaters may be placed on a flat level surface made of material that can resist heat. Hardwood, plywood, concrete, etc. are acceptable. They should not be mounted directly on a carpeted floor. Use a solid platform or rigid heat resistant material between the carpet and the heater.

Ideally a large open space would best suit the heater. The surfaces of the heater and the flue stack will be generating heat and should be taken into consideration when mounting the heater.

The minimum standard clearance between the Trekker and any building construction other than the floor is 16 inches (40 cm). The minimum standard clearance between the exhaust vent pipe and any building construction is 16 inches (40 cm). The minimum standard clearance between the Expedition heater and any building construction other than the floor is 24 inches (60 cm). The minimum standard clearance between the Prospector and any building construction other than the floor is 36 inches (91 cm). The minimum standard clearance between the exhaust vent pipe of both the Expedition and the Prospector and any building construction is 18 inches (45 cm).

An unlevelled heater will not operate properly and could be dangerous. Adjust the heater perfectly level in all directions before mounting. The heater should be securely mounted to the floor. The legs contain a 1/4" hole for directly fastening the heater to the floor. .

Exhaust Flue Stack (General application)

OIL BURNING APPLIANCES MUST BE CONNECTED TO FLUES HAVING SUFFICIENT DRAFT AT ALL TIMES TO ASSURE SAFE AND PROPER OPERATION OF THE BURNER. All heaters must be installed according to the installation rules mandated by local, state/provincial, and federal government authorities. These regulations deal with various matters including heater and flue set backs and fuel storage. DO determine what regulations apply in your local area. DO NOT install the heater or the exhaust flue stack unless the installation conforms with the regulations governing your location. The Pioneer heaters do not come with an exhaust flue stack. Blue stove pipe or All-Fuel "L" type vent capable of continuous use for flue gas temperatures up to 1000°F may be used.

Always use flue stacks that are at least the same diameter as the flue collar on the heater. Appropriate parts for the appropriate flue stack must be purchased at your local heating and ventilation companies. As all installations differ, it is necessary that you follow all local, state/provincial, and federal guidelines in selecting the type, method, and location of the exhaust flue stack for your particular situation. Before the hooking up of the heaters to a chimney, check to make sure the chimney is in good condition and that the flue pipe will allow sufficient draft. A maximum horizontal length of 6' is allowed. Make sure to have a 1/4" slope per foot minimum. Do not use more than two 90° elbows for connecting stove to chimney. The recommended draft for the Trekker is between .030-.045 inches water column. This is measured 18" (45cm) up the stack and before the draft regulator. The minimum flue stack height is 6 ft (1,8m). The recommended draft for the Expedition and Prospector is between .040-.060 inches water column. The minimum flue stack height of both is 9 to 12 feet (3,6m).

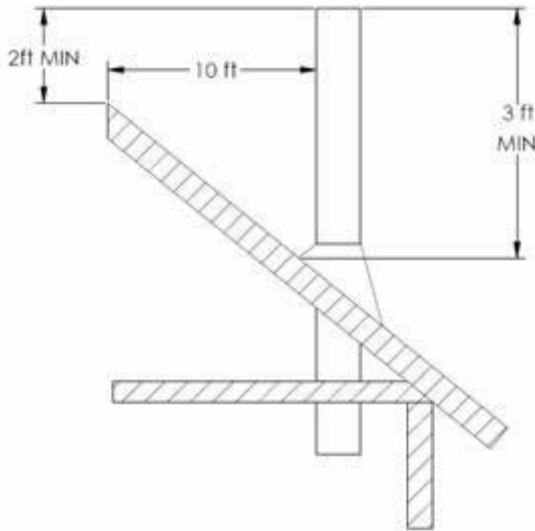

The chimney flue should extend at least 2 ft (0,6m) above the highest roof surface or structure within 10 ft (3,0m) horizontally of the chimney to prevent down drafts.

Attach the female part of the flue pipe to the heater using 3 self tapping screws space equally around the pipe

Install the included draft regulator which is necessary in order to maintain stable draft in certain

conditions.

Read the installation and adjusting instructions which are packed in the carton of the draft regulator before installing.

The **Pioneer** heaters emit very little carbon and soot into the flue system. However it may be convenient to design your flue system so it can be brushed clean if necessary. For safe operation, it is highly recommended that the installed exhaust system be inspected by a qualified professional to ensure the suitability of the type and method of the installation.

Exhaust Flue Stack for Tent or Portable building ONLY

The Pioneer heaters can be installed in tents or portable buildings (both heat and/or fire resistant) using the optional exhaust kit. The exhaust kit is designed for exhausting through the roof of the tent or portable building.

The following are general guidelines for venting through this type of structure.

Some tents and portable buildings have a stovejack or protected opening in the roof for the passage of an exhaust flue stack. This opening and the surrounding area is protected from damage by heat by either insulated material or heat radiation shields.

Only structures with these devices installed should be used. The optional exhaust kit is supplied with two, three foot sections of 3 inch diameter, single wall flue stacks and a rain cap. When assembled, the exhaust stack is inserted into the opening and the rain cap is installed and secured on top of the last section of stack. Tie one end of a guy line through the loop on one of the three wire ropes located on the rain cap. Use an overhand loop to secure the wire. Lower the assembled stack with the attached rain cap and secure it onto the flue stack adapter on top of the heater. Position the stack vertically and secure it in place by attaching each of the three guy lines to the ground or building.

Always place the heaters a safe distance from the tent or portable building wall on a certified fireproof mat or bricks. Swivel the legs outwards for a

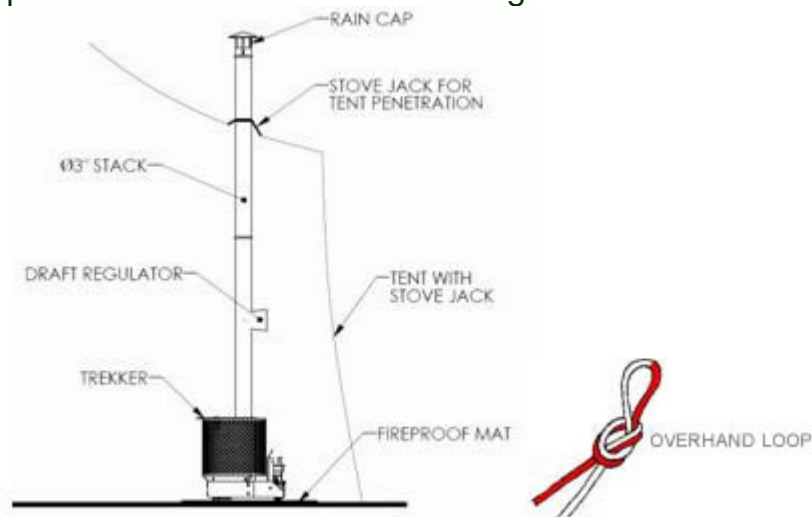

stability.

Note:

- ▣ The exhaust system must develop the recommended draft.
- ▣ When going through combustible material, all local codes for insulated stacks, protective shield clearances, etc. must be met.

During operation, the heater produces harmful carbon monoxide (CO) and other gases. To prevent CO poisoning, ensure the exhaust stack sections fit together snugly and that the exhaust gases are properly vented through the roof of the structure.

Venting and Air Supply

The heaters consume about 4000 ft³ of air per 1 US gallon of oil. This air enters the heater through the air inlets and exits the chimney as combustion gas. They should be installed in a well ventilated area that allows the entrance of outside fresh air.

Connecting to Oil Tank

The external oil tank is to be installed in accordance with the manufacturer's instructions and the Standard to which the tank has been manufactured.

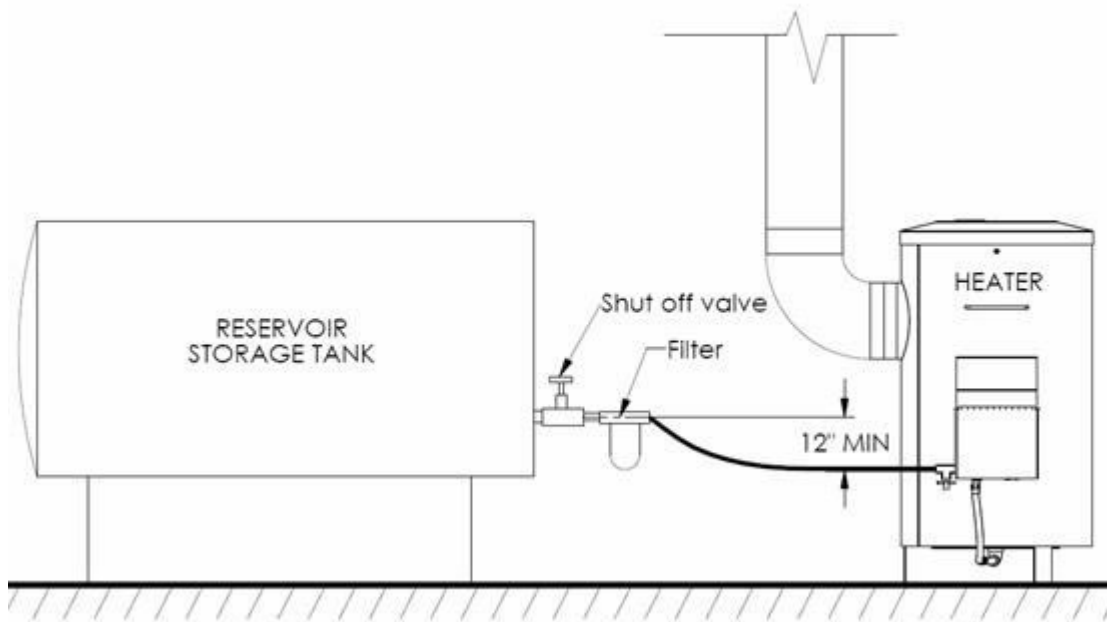

Make sure that the tank outlet is 12 inches (305mm) higher than the inlet of the oil control valve. (Gravity fed)

A good quality filter should be placed at the tank to ensure a good clean supply of oil to your heater.

When the tank is installed outdoors, it is preferable to use oil #1, to avoid any viscosity problems.

DO NOT use an oil/fuel tank inside a tent or portable building.

The fuel line can be connected to the oil control valve using a ¼" NPT male fitting.

INSTALLATION OF THE HEATER, FLUE STACK AND FUEL TANK MUST BE INSTALLED IN ACCORDANCE WITH THE REGULATION OF AUTHORITIES HAVING JURISDICTION, NFPA #31, CSA STANDARD B139. AND UL896.

Please contact Exploration Tents by using our” CONTACT US Page”

the first time and you will be provided our E-Mail address at that time,

Thank you,

BUSH-RAT TESTED and APPROVED

Made in Canada

www.explorationtents.com

